

**“Global/Local Innovations for Next Generation Automobiles”
Invited Lecture Oct. 28, 2015**

Multi-Fuel Engine Project

**Kazuhiko KAMI
President & Representative Director
Hana Engineering Japan K.K.**

“Multi-Fuel Engine Project”

-Conducted since 2013 under “Next Generation Automobiles –Miyagi Area,” a regional innovation program of Industry-Academia Collaboration funded by MEXT

-Primary members include following labs. of Tohoku Univ. and regional companies:

Miyamoto Lab.,

Kuriyagawa Lab.,

Yoshikawa Lab.,

Hana Engineering Japan K.K. (Sendai),

My Car Plaza Corp. (Hanamaki, Iwate), and

Kyoyu K.K. (Sendai)

Leader of Shale Gas Revolution

Ideal next generation engine exceeding DDF (Diesel Dual Fuel) engine and Gas mono combustion engine

That is:

Multi-Fuel Engine

Novel technology bringing dramatic improvement in fuel efficiency and high environmental performance while maintaining high power torque of diesel engine

***PCT Appl. filed on Feb. 10, 2015**

What is Next Generation Automobile?

- The World is interested in super capacitor EV or FCV for next generation motorcars.
- However, motor driven FCV is not suited for buses and tracks.
- Only diesel engine can provide drive source for mid-size buses and tracks that need large torque.
- However, diesel engine has low environmental performance and produces lots of harmful exhaust materials.
- Upon Shale Gas Revolution started in the U.S., we think of Multi-Fuel Engine that brings high environmental performance and is suited for mid- and large size buses and tracks, and we move to production.

Problem with Diesel Engine

It has changed from visible PM to “invisible” PM.

- **Diesel engine of previous generation**
PM (Particulate Matter): Regulation became severe. Ex.) Eight Regional Government Ordinance obligates automobiles entering the regions to equip with PM reduction system.
- **Current diesel (advanced) engine – Common Rail System**
Refinement of fuel by common rail system lead to increase of nano PM by several ten thousand times. PM merely became invisible.

In Europe, according to announcement, increase in deaths relate to increase in nano PM due to common rail system.

Nano PM invade into not only circulatory organ such as heart, brain, and nerve system but also sexual organ

Fundamental step
to suppress PM

Engine for automobile, ship and generator, using natural gas does not produce PM

Technology to lower environmental pollution: CNG mono fuel combustion and CNG-DDF

Drive around filing station

Drive among cities at long ranges

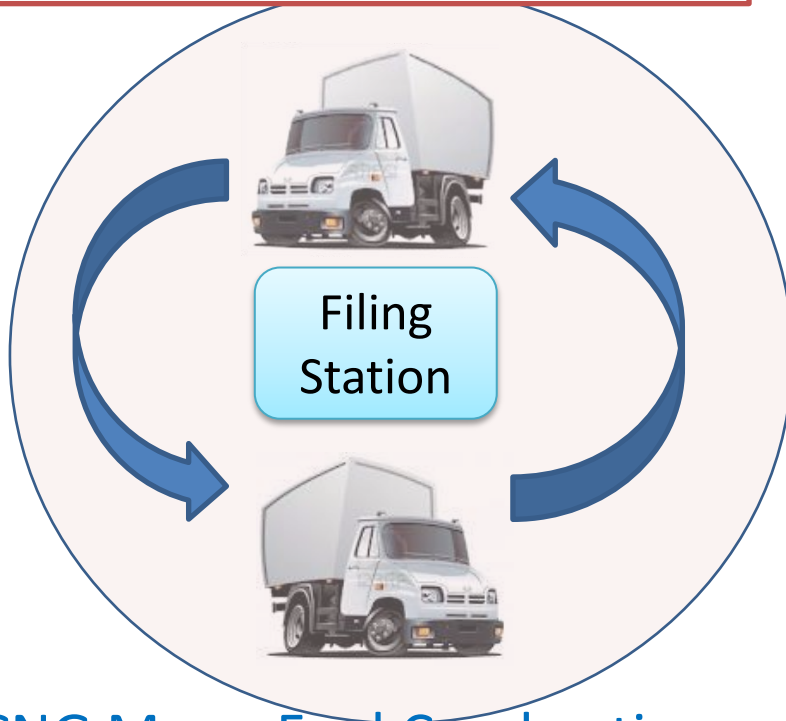

CNG Mono Fuel Combustion

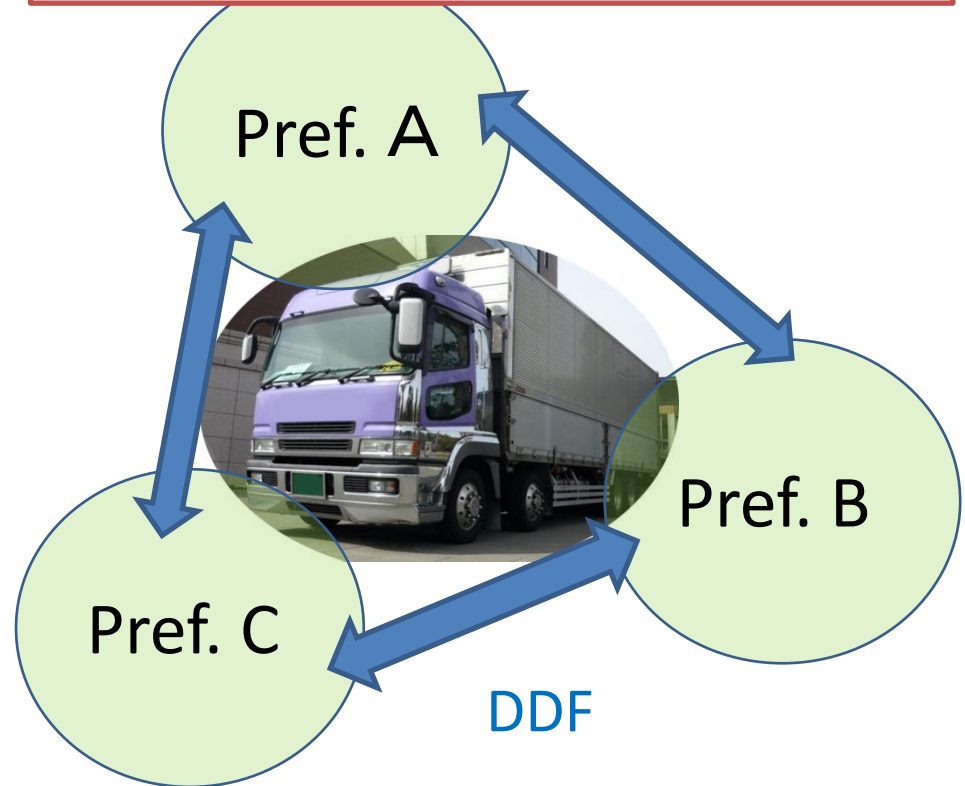

CNG : Compressed Natural Gas

LNG : Liquefied Natural Gas

If LNG supply system established, drive ranges of both types expanded.

2, 3, 5, 8: Gas mono fuel combustion cylinder

1, 4, 6, 7: DDF combustion cylinder

11: Natural gas tank

12: Light oil tank

13, 14: Valve

16, 17, 18: Injector

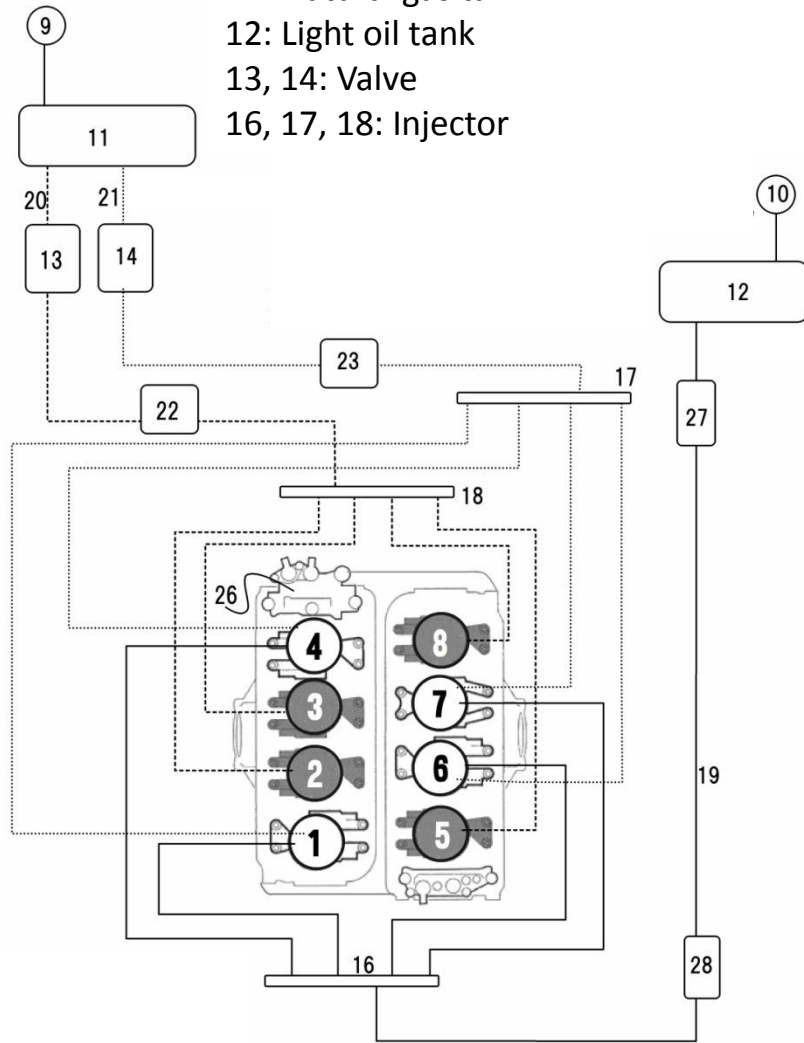

Schematics of MF Engine

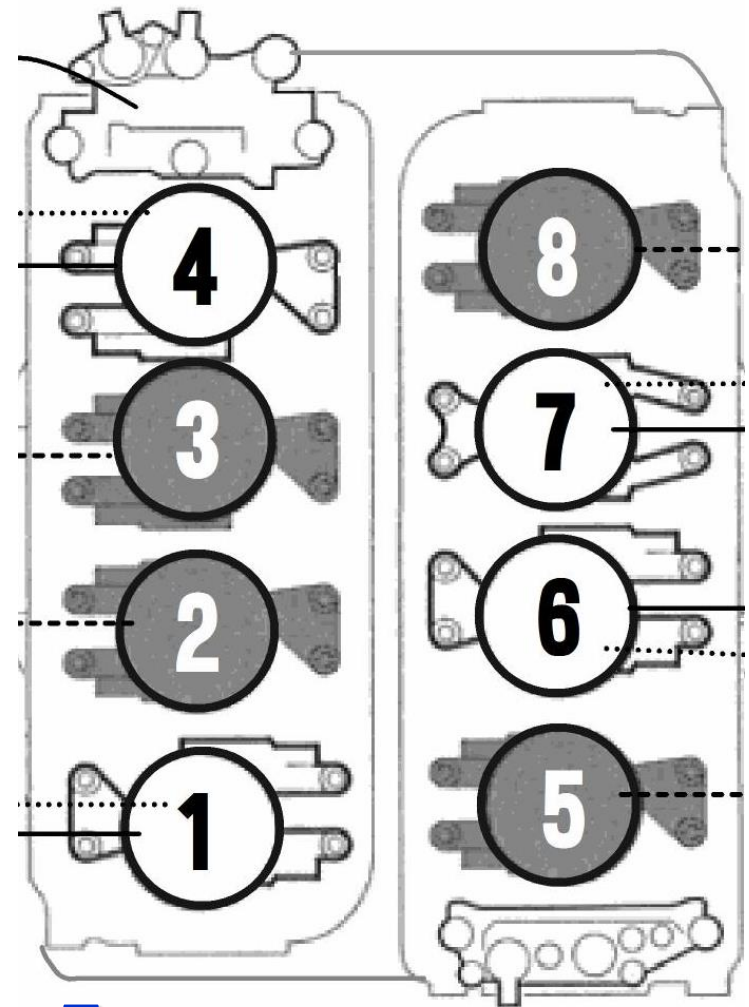

V8 Cylinder Type

Operation of 4 Cylinder MF Engine (By animation)

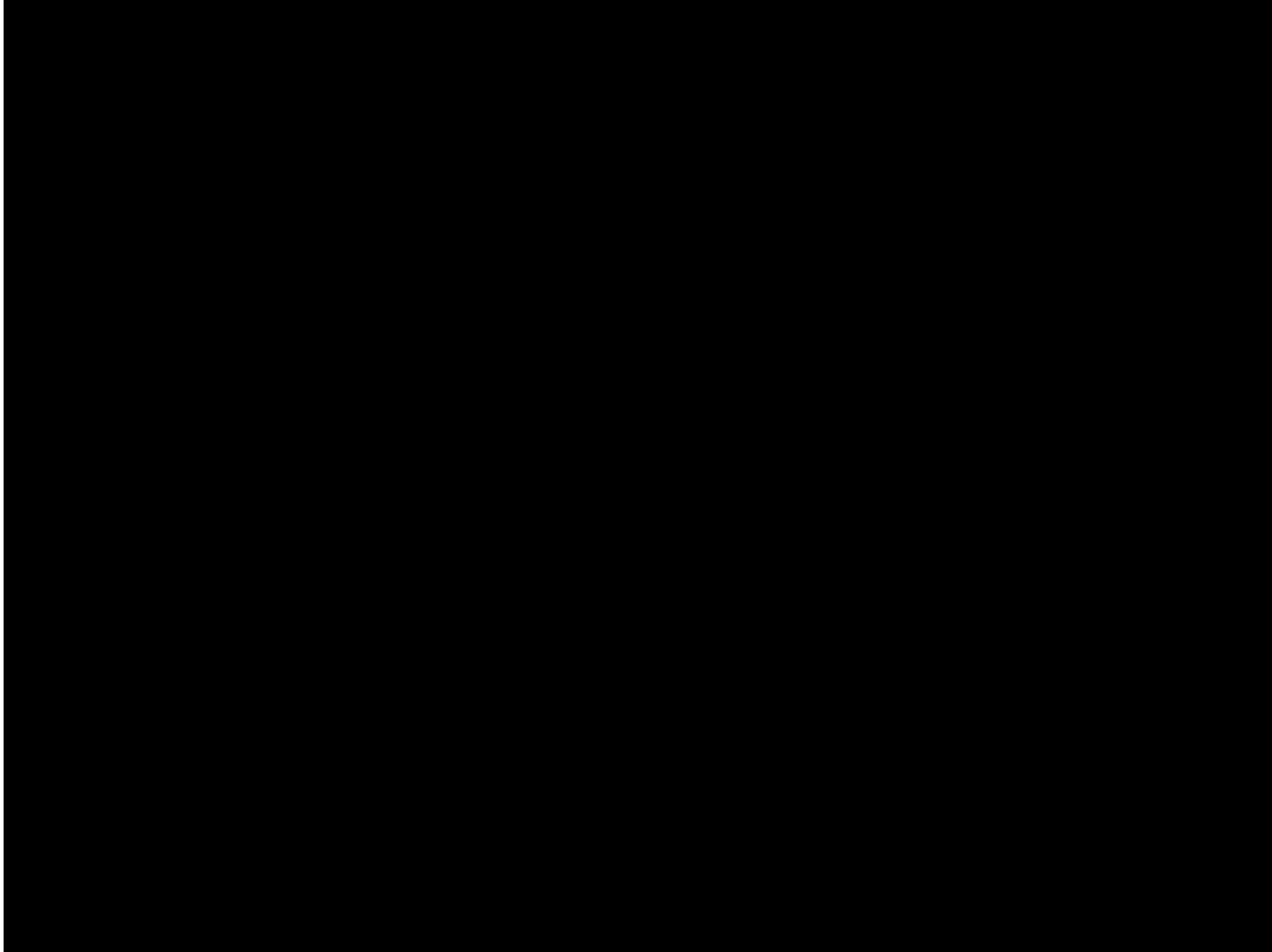

Cylinder head, variable valve system, balance shaft, input/output clutch, etc. need to be newly developed

Variable valve system

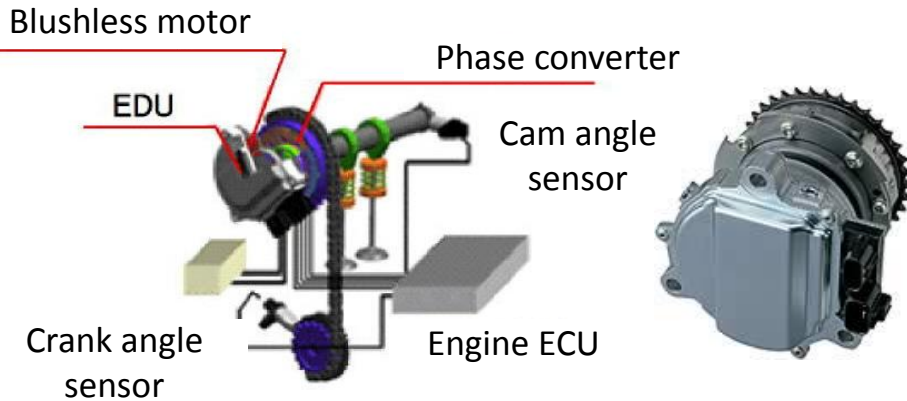

Balance shaft

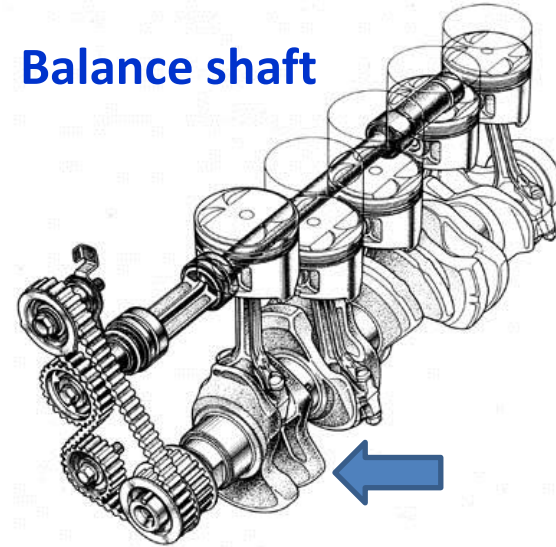

Input/output clutch (torque converter)



Cylinder head

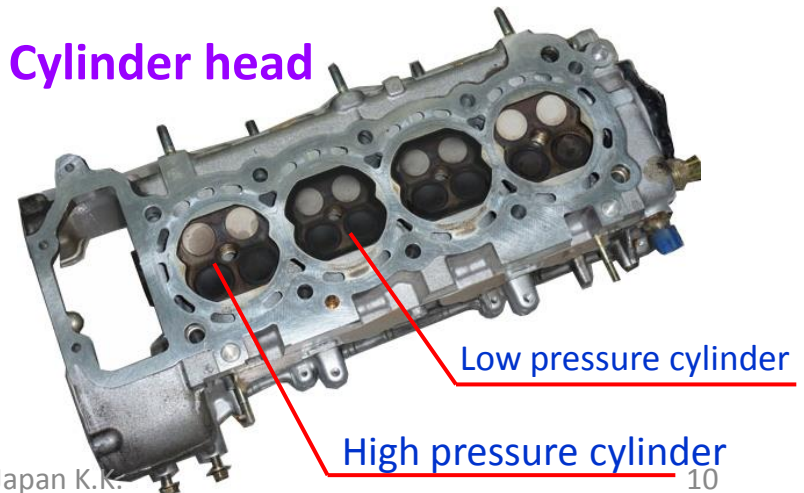

Summary

Multi-Fuel Engine:

- Has high environmental performance comparable to super capacitor EV system or fuel cell system for motorcars;
- Can suppress nano PM that undermine human beings' health and lives;
- Is a landmark engine that may cause revolution of fuel suited for harmony with shale gas revolution; and
- Is a next generation engine that the world has been waiting for and not just for Japan.

Thank you for your attention.